

REPORT OF

PRODUCT EVALUATION

CONDUCTED ON A

"COMPONENT GLASS"
ALUMINUM GUARDRAIL ASSEMBLY

TO THE

INTERNATIONAL BUILDING CODE 2000

FOR

EXCELL RAILING SYSTEMS LTD.
#406 - 12914 ANVIL WAY
SURREY, BC V3W 8E7

REPORT PREPARED BY

INTERTEK TESTING SERVICES NA LTD.
WARNOCK HERSEY
211 SCHOOLHOUSE STREET
COQUITLAM, BC V3K 4X9

REPORT NUMBER: 481-1456 - 4c

DATE: MARCH 6, 2000
REVISED DATE: SEPTEMBER 16, 2002
UNDER PROJECT NO.: 3028343-4



Revised Date: September 16, 2002

TABLE OF CONTENTS

	PAGE
TABLE OF CONTENTS	1
PREFACE	2
INTRODUCTION	3
DESCRIPTION	3
CODE REQUIREMENTS	4
TEST RESULTS	4
ONE PIECE TOP RAIL	4
CONCLUSION	5
APPENDIX A – DETAILS OF THE TESTED SYSTEM	7 PAGES
APPENDIX B – DETAILS OF THE ALTERNATE ONE-PIECE RAIL	1 PAGE

TABLE OF REVISIONS

DESCRIPTION	PAGE
August 7, 2002	
Report Pages Renumbered	All
Table of Contents updated	1
Table of Revisions added	1
Preface Revised	2
Introduction revised to include one-piece top rail and IBC Acceptance	3
IBC Code Requirements replaced BOCA National Building Code	4
Test Results simplified to correlate with IBC Requirements	4
Evaluation of one-piece Top Rail added	4
Signatures Revised	4
Appendix B added	--

Revised Date: September 16, 2002

PREFACE

All services undertaken are subject to the following general policy:

1. This report is for the exclusive use of Intertek Testing Services NA Ltd.'s (ITS's) client and is provided pursuant to the agreement between ITS and its client. ITS's responsibility and liability are limited to the terms and conditions of the agreement. ITS assume no liability to any party, other than to the client in accordance with the agreement, for any loss, expense or damage occasioned by the use of this report.
2. Only the client is authorized to copy or distribute this report and then only in its entirety. Any use of the ITS name or one of its marks for the sale or advertisement of the tested material, product or service must first be approved in writing by ITS.
3. The observations and test results in this report are relevant only to the sample tested. This report by itself does not imply that the material, product or service is or has ever been under an ITS certification program.

Revised Date: September 16, 2002

INTRODUCTION

Intertek Testing Services NA Ltd./Warnock Hersey has conducted Uniform and Concentrated load tests on an aluminum guardrail assembly manufactured at Excell Railing Systems Ltd. manufacturing plant in Surrey, BC. The rail assembly was identified as the "Component Glass System (42" Height)" and was tested on January 19, 2000.

The testing was conducted to determine if the Guard Rail Assembly is in accordance with the BOCA National Building Code /1999, sections 1615.8.2 "Guard Design and Construction" and 1615.8.2.1 "In-fill Areas".

A further engineering evaluation of the section properties of the one piece Excell Round and Excell Square Welded Pick top rail was conducted on July 30, 2002 as part of Project No.: 3028343. This evaluation was to determine if the one-piece rail system would perform as well or better than the two-piece section. Finding that the one-piece system is an acceptable alternate it has been included in this report.

In addition to the above, an evaluation was conducted to determine if the guardrail assembly meets the load requirements of the International Building Code 2000 (IBC), Section 1607.7.1.

DESCRIPTION

The guardrail is (120") wide measured from corner post to corner post (which includes an intermediate post at mid-span) and is (42") high measured from deck level to the top of the guardrail.

The top rail is constructed in two pieces consisting of a sub-rail and a snap-on Square Top Rail cap. The sub-rail is fastened to the top of each corner post using two #12 x 1-1/2" panhead screws. The corner sleeve portion of the top cap is mitre cut and welded and extends approximately 4" to either side. Each top cap runs continuously from one 90° corner segment to the other. Where the top and bottom rails attach to the building wall structure a wall attachment plate is provided.

A 2-1/2" wide x 3" high x 1/8" aluminum plate assembly (complete with 1-1/2" long welded sleeve) is fastened to the end of the top rail using two #12 x 1-1/2" panhead screws and three #14 x 2" panhead screws (complete with Mungo brand, model MN8x40 sleeve anchors) which secure the wall attachment plate to the concrete wall structure. A 1-1/2" wide x 2-7/8" high x 1/8" thick aluminum plate assembly is fastened to the end of the bottom rail using a single #8 x 3/4" self tapping panhead screw and two #14 x 2" panhead screws (complete with Mungo brand, model MN8x40 sleeve anchors) which secure the wall attachment plate to the concrete wall structure. The bottom rails are fastened to a 1" long extruded aluminum rail clip using a single #8 x 3/4" self tapping panhead screw. Each of the rail clips, located on either side of each post, are fastened to the post using two #12 x 1-1/2" panhead screws.

A tempered glass panel 0.222" (5.65mm) thick is supported between the top sub-rail and the tapered channel shaped bottom rail. A co-extruded vinyl sleeve is provided within both the top sub-rail channel and the bottom rail channel. The vinyl sleeve in the top channel is approximately 1" deep. The vinyl sleeve in the bottom channel is approximately 1/2" deep.

The corner posts are 1-5/8" square complete with a screw chase at each inside corner and mid-section with a wall thickness of 0.068" thick. An aluminum baseplate measuring 3-1/2" x 3-1/2" x 1/4" thick was fastened to the base of each post using four #12 x 2" hardened steel flathead tapping screws (Robertson Whitehouse Type "A"). Four #14 x 2" panhead screws (complete with Mungo brand, model MN8x40 sleeve anchors) secure each post to the concrete floor. Supporting the bottom rail midway between the posts are 1/2" square (0.060" wall thickness) aluminum picket support leg which is snapped into the underside of the bottom rail and secured using a single #8 x 1/2" self tapping screw. Each leg is fastened to the concrete floor using a #12 x 2" panhead screw (complete with a Mungo brand, model MN8x40 sleeve anchor). See attached drawings in the Appendix for details and a general layout.

CODE REQUIREMENTS

Revised Date: September 16, 2002

International Building Code 2000

1607.7.1 Handrails and guards. Handrail assemblies and guards shall be designed to resist a load of 50 pounds per linear foot (pound per foot) (0.73 kN/m) applied in any direction at the top and to transfer this load through the supports to the structure.

Exceptions

1. For one-and two-family dwellings, only the single concentrated load required by Section 1607.7.1.1 shall be applied.
2. In Groups I-3, F, H and S occupancies, for areas that are not accessible to the general public and that have an occupant load no greater than 50, the minimum load shall be 20 pounds per foot (0.29 kN/m).

1607.7.1.1 Concentrated load. Handrail assemblies and guards shall be able to resist a single concentrated load of 200 pounds (0.89 kN), applied in any direction at any point along the top, and have attachment devices and supporting structure to transfer this loading to appropriate structural elements of the building. This load need not be assumed to act concurrently with the loads specified in the preceding paragraph.

1607.7.1.2 Components. Intermediate rails (all those except the handrail), balusters and panel fillers shall be designed to withstand a horizontally applied normal load of 50 pounds (0.22 kN) on an area not to exceed 1 square foot (305 mm²) including openings and space between rails. Reactions due to this loading are not required to be superimposed with those of either preceding paragraph.

1607.7.1.3 Stress increase. Where handrails and guards are designed in accordance with the provisions for allowable stress design (working stress design) exclusively for the loads specified in Section 1607.7.1, the allowable stress for the members and their attachments are permitted to be increased by one-third.

The required safety factor for proof tested assemblies is 2.5 in accordance with clause 1714.3.1.

The safety factor for glass used in handrails and guards is 4 in accordance with clause 2407.1.1.

TEST RESULTS

1. A horizontal load of 125 lbs/ft was applied to the top rail without failure.
2. A horizontal concentrated load of 500 lbs was applied to the top rail without failure.
3. A horizontal load of 200 lbs was applied over a one-foot square area of the glass infill without failure.

ONE PIECE TOP RAIL

An engineering evaluation was conducted to determine if the Excell Round and Excell Square one-piece welded picket top rails are equivalent to the two-piece system that was initially evaluated.

The one-piece system was found to be an acceptable alternate based on the following:

1. Testing of the initial system revealed that the two-piece assembly did not work as a composite section.
2. The lateral section properties (Moment of Inertia) of the one-piece system exceed that of the top cap section of the two-piece system. The top cap provides the majority of the lateral stiffness of the system.
3. The addition of the integrated bottom plate to the one-piece system significantly increases the buckling capacity of the rail.

Revised Date: September 16, 2002

CONCLUSION

The guardrail system and installation as described in this report (and attached drawings) meets the loading requirements of the International Building Code 2000, clause 1607.7.1 with a minimum safety factor of 2.5 for metal components and a minimum safety factor of 4 for the glass panel.

INTERTEK TESTING SERVICES NA LTD.
Warnock Hersey

Tested by: No longer with the Company
Doug Docherty, ASCT
Senior Technologist - Building Products

Reviewed by: C. K. ROBINSON
Cam Robinson, P. Eng.
Manager, Construction Products

CR/lrh

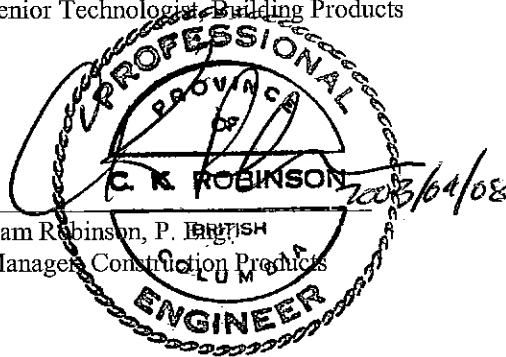

APPENDIX A
Details of the Tested Systems

COMPONENTS

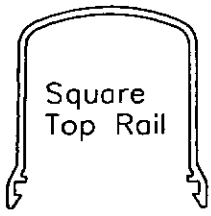

Square Top Rail

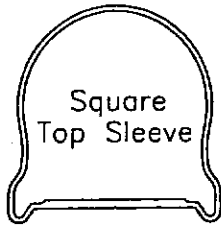

Square Top Sleeve

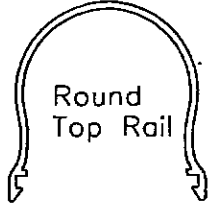

Round Top Rail

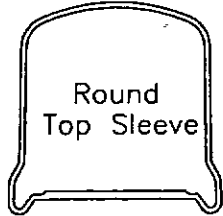

Round Top Sleeve

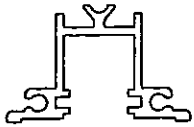

Top Rail Receiver

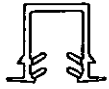

Top Rail Glass Insert



Bottom Rail Glass Insert

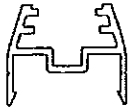

Bottom Rail



Rail Clip

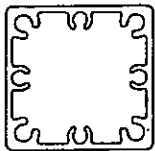

1-5/8" Square Post

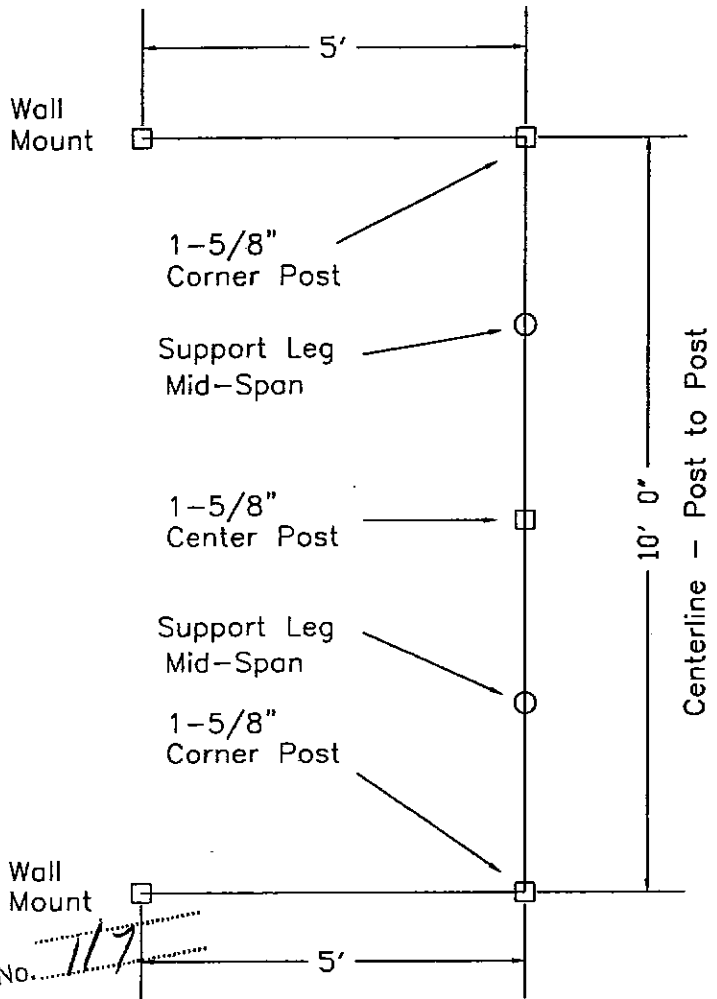

DWG No. 117

APR 26 2000

APP BY [Signature]

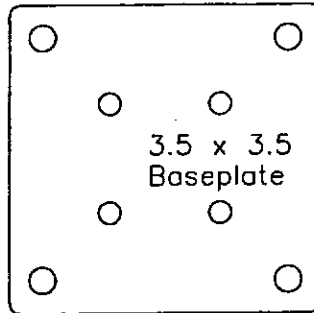

3.5 x 3.5 Baseplate

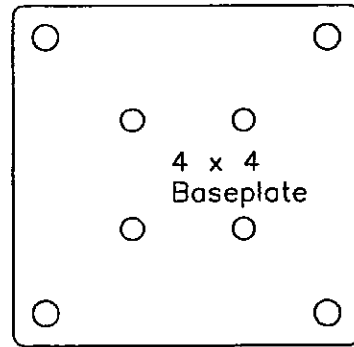

4 x 4 Baseplate

#406 - 12914 Anvil Way Surrey, B.C. CANADA V3W 8E7 Bus.(604) 501-0151 Fax.(604) 501-0155

TITL Component Glass System @ 42" Height		
SCALE 3/8" = 1'	DATE Jan.2000	N.B.C. 120" Centerline
DRAFT P.Bacon	CHK'D	U.B.C. 120" Centerline
ENG.	CHK'D	BOCA 120" Centerline
APPR'D	AS BUILT	JOB No.

Excell Railing Systems Ltd. TM

DRAWING No. 004



CUSTOMER DMJ HOLDINGS	CUSTOMER PART NO.	DIE NO. VS-36225A
DESCRIPTION TOP CHANNEL (GLASS)	DIE LOC.	DASH NO.
STANDARD TOLERANCES TO APPLY UNLESS OTHERWISE SPECIFIED	BACKER LOC.	PROPOSAL NO. 9341A-1

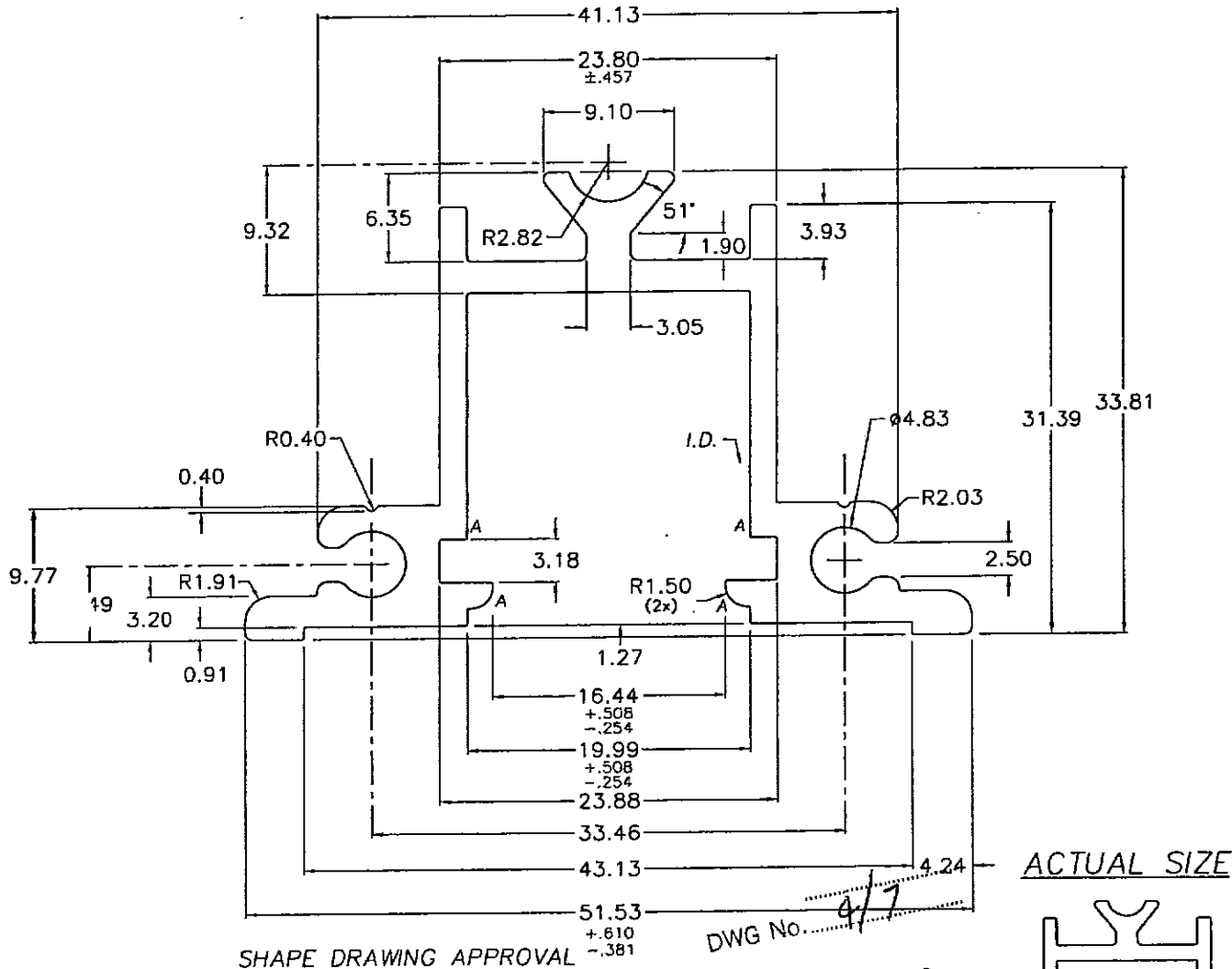

SHAPE DRAWING APPROVAL

Please signify below that shape and dimensions conform to your requirements and that you agree to accept all legal responsibility for patent, trademark, copyright, industrial design, or any other infringement relating to this shape and to indemnify and save harmless Caradon Indalex from any claims, suits, actions or demands arising therefrom.

Signed by:
Date:

DWG No. **4/7**
APR 26 2000
APP BY *[Signature]*

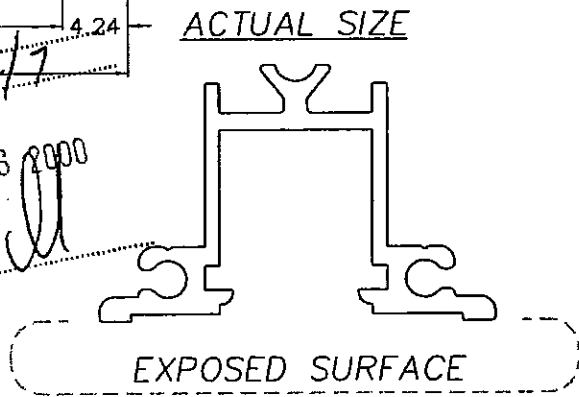

Caradon Indalex A division of Caradon Limited TORONTO - MONTREAL - CALGARY - VANCOUVER										DIE NO. VS-36225A
EST. AREA	0.492 IN ² 317.72 MM ²	OUT PER.	N/A IN N/A MM	12/10/99	(A)	Remove 2 nibs, round edge of 2	BW			
EST. WT.	0.591 LBS/FT 0.862 KG/M	WALLS - SHOWN	±.18 EXCEPT AS SHOWN							
EST. PER	11.036 IN. 280.32 MM	C.C.D.	2.102 IN 53.39 MM							
OWN BY	WL CAVITIES -	SCALE	2:1	DATE	99/12/10					
DIE SIZE	PKT.	LIP	BACKER SIZE	BACKER NO.	BOLSTER					

CUSTOMER DMJ Holdings	CUSTOMER NO. 2401	PROPOSAL# 9209A-1	DIE NO. VH-11722A
		CLASSIFICATION#	
DESCRIPTION: Post	DATE	SYM	REVISION

PRODUCTION COPY ONLY

INDALEX I.D. R0.203 x 0.203 High (2x)

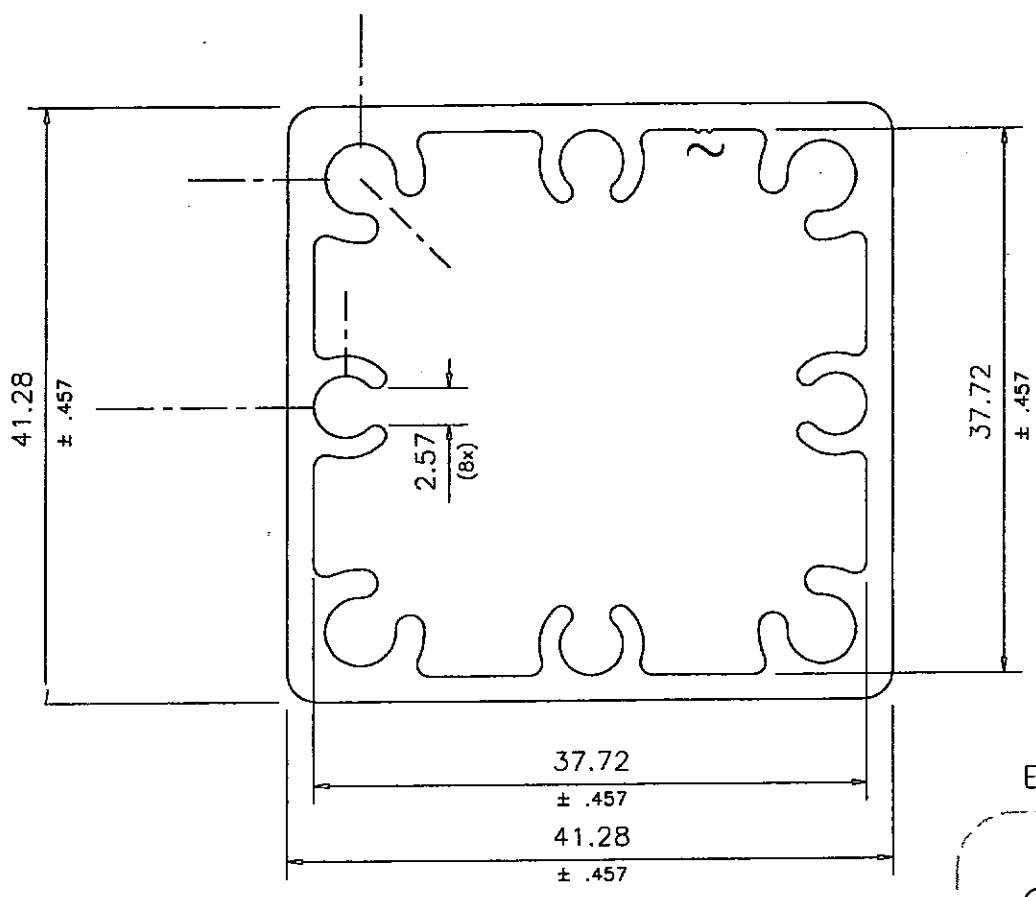

Exposed All Around

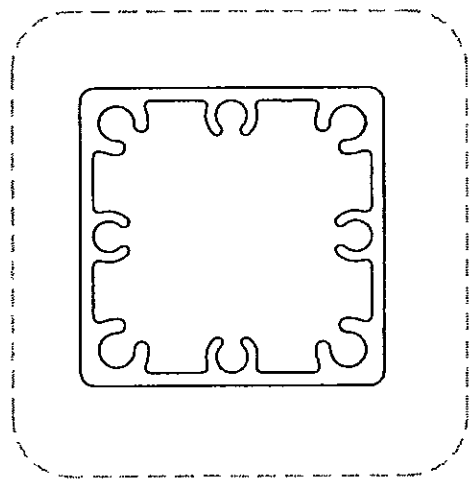

Actual Size

DWG No. 5/7
 APR 26 2000
 APP BY [Signature]

Caradon Indalex

WALL THICKNESS 0.070 IN 1.79 MM EXCEPT AS SHOWN			
EST. AREA 0.689 IN ²	444.52 MM ²	OUT PER. 6.365 IN	161.67MM
EST. WT. 0.827 LBS _T	1.206 KG _M	FACTOR 20 /	350
EST. PER. 16.610 IN	421.90 MM	C.C.D. 2.265 IN	57.54 MM
DWN BY <u>W.Lam</u>	ALLOY 6005A-T61	SCALE 2:1	DATE 99/06/23

NOTE

CHECK OR INDICATE EXPOSED SURFACES, CIRCLE CRITICAL DIMENSIONS
 INDICATE LOCATION FOR CARDON INDALEX IDENTIFICATION MARK

SHAPE DRAWING APPROVAL

PLEASE SIGNIFY BELOW THAT THE SHAPE AND DIMENSIONS CONFORM TO YOUR
 REQUIREMENTS AND THAT YOU AGREE TO ACCEPT ALL LEGAL RESPONSIBILITIES FOR
 PATENTS, TRADE MARK, COPYRIGHT, INDUSTRIAL DESIGN OR ANY OTHER INFRINGEMENT
 RELATING TO THIS SHAPE AND TO INDEMNIFY AND SAVE HARMLESS CARADON
 INDALEX FROM ANY CLAIMS, SUITS, ACTIONS OR DEMANDS ARISING THEREFROM.

SIGNED BY:

DATE:

RRFAK ALL CORNERS .010"R (0.25R) UNLESS OTHERWISE NOTED.

STANDARD TOLERANCES TO APPLY UNLESS OTHERWISE SPECIFIED

CUSTOMER DMJ Holdings	CUSTOMER NO. 2401	PROPOSAL# 9209-3	DIE NO. VS-11724A
	CLASSIFICATION#		
DESCRIPTION: Attachment Clip	DATE	SYM	REVISION

~ INDALEX I.D. R0.203 x 0.203 Deep (2x)

PRODUCTION COPY ONLY

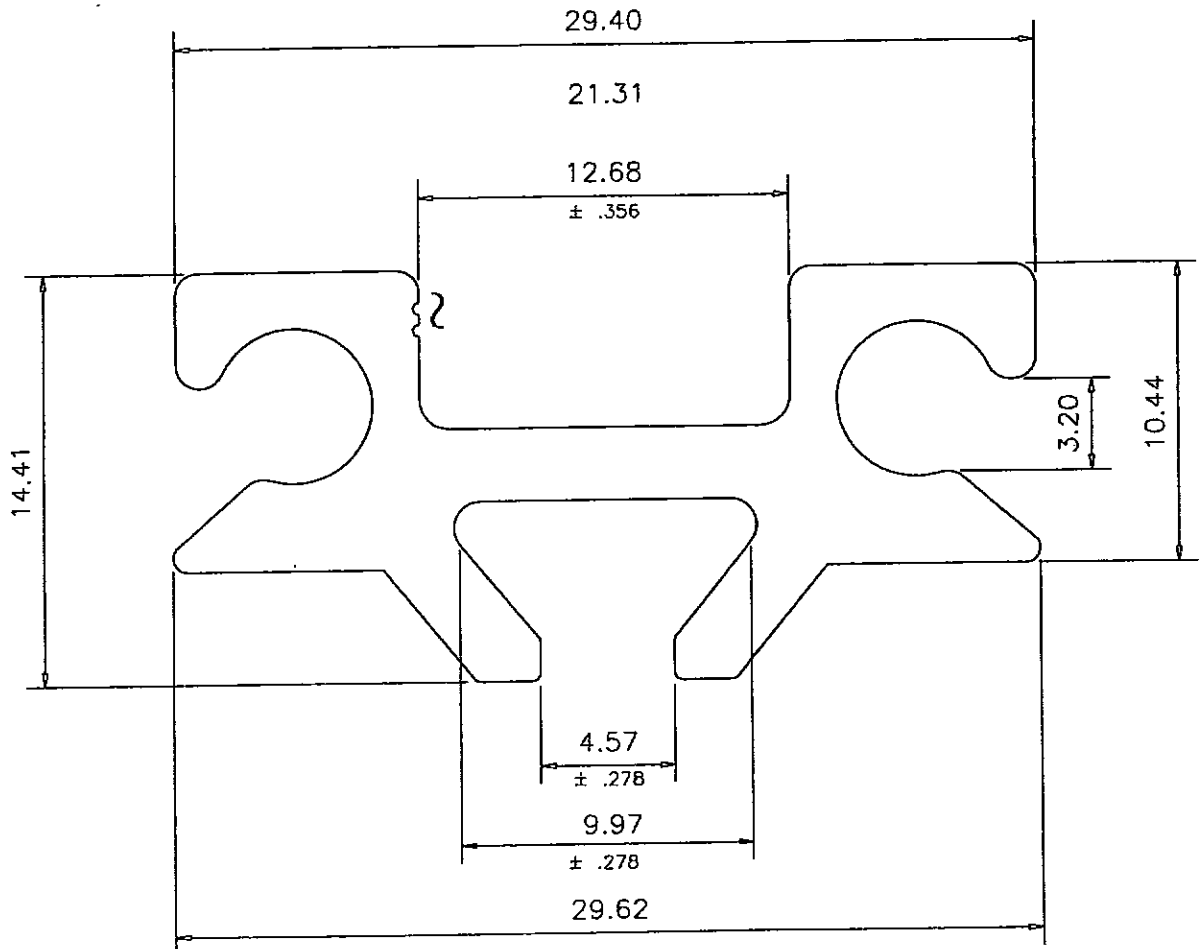

NO EXPOSED SURFACE

DWG No. 67
 APR 26 2000
 APP BY [Signature]

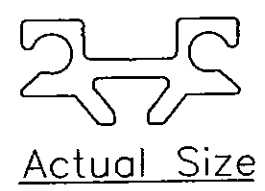

NOTE: Contact customer prior to re-ordering dies.

Caradon Indalex		PRICING: <input type="checkbox"/> WT. <input type="checkbox"/> PC.	PLUGGING RATIO: <input type="checkbox"/> 1 <input type="checkbox"/> 2 <input checked="" type="checkbox"/> 3	LID. NITROGEN <input checked="" type="checkbox"/> YES <input type="checkbox"/> NO.
		DIE SIZE: 9 x 1.5"	PKT. 1/2"	DIE LOC.
WAL THICKNESS 0.100 IN 2.54 MM EXCEPT AS SHOWN		BACKER SIZE: 9 x 4"	FEEDER SIZE.	
EST. AREA 0.270 IN ² 174.16 MM ²	OUT PER. 0.000 IN 0.00 MM	BACKER NO. 40300	FEEDER NO.	
EST. WT. 0.324 LBS 0.472 KG	FACTOR 17/290	BACKER LOC.	FEEDER LOC.	
EST. PER. 5.389 IN 136.87 MM	C.C.D. 1.217 IN 30.90 MM	BOLSTER NO. C401(K16)	HIM SIZE.	CAV. 4
DWN BY <u>B. White</u>	ALLOY 6063-T5	SCALE 4:1	DATE 99/07/05	PRESS NO. 2
BREAK ALL CORNERS .010"R (0.25R) UNLESS OTHERWISE NOTED.		CONT'R 188	EXT. RATIO 40	
STANDARD TOLERANCES TO APPLY UNLESS OTHERWISE SPECIFIED				

APPENDIX B
Details of the Alternate One-Piece Rail

