

PVC METAL DRIP EDGE

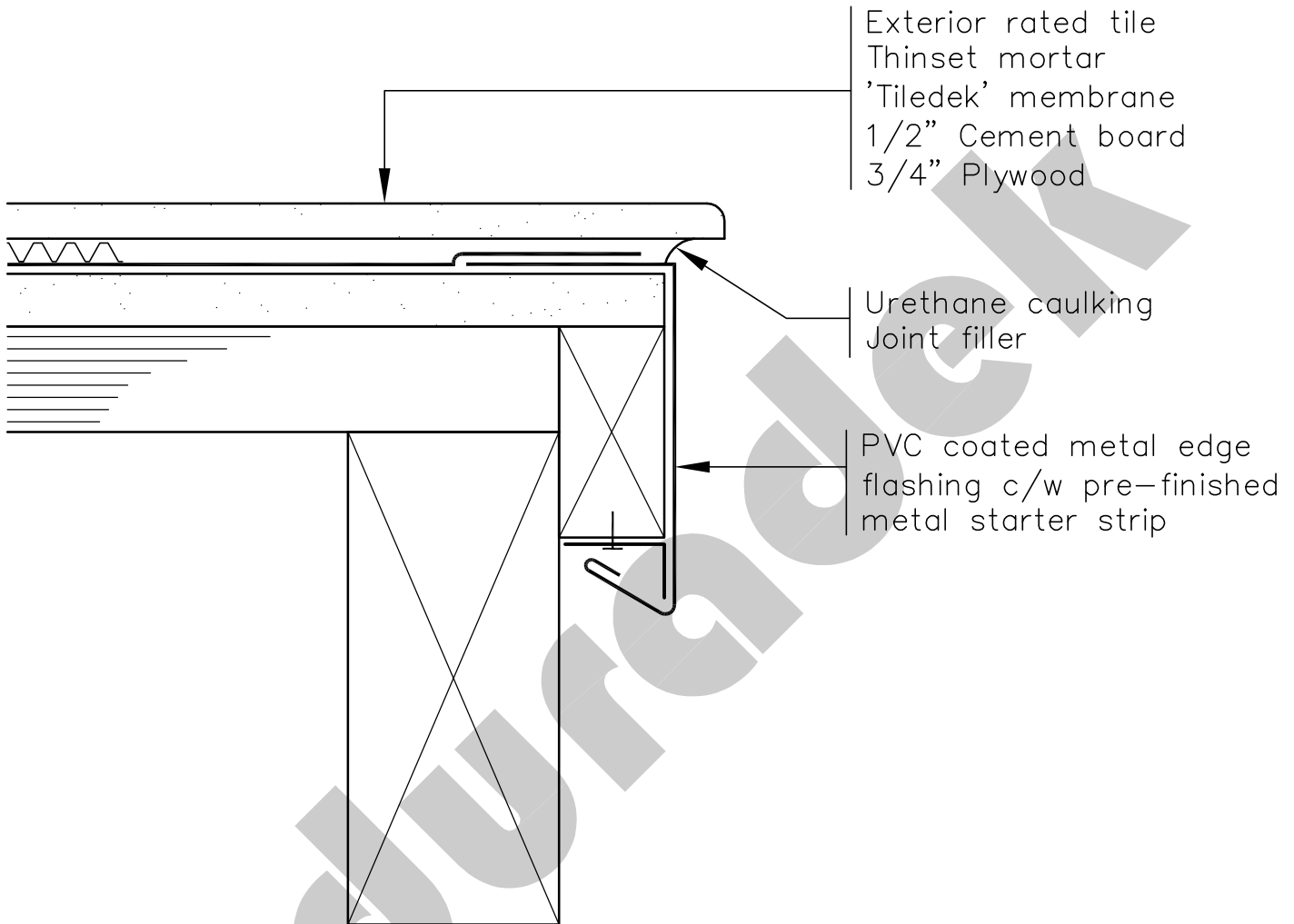

NOTE:

AS A SUPPLIER OF FINISHED PRODUCT ONLY, DURADEK LTD. DOES NOT ASSUME RESPONSIBILITY FOR ERRORS IN DESIGN, ENGINEERING, OR DIMENSIONS. THE ARCHITECT, ENGINEER, SPECIFIER, CONTRACTOR OR OWNERS' REPRESENTATIVE MUST VERIFY ALL DIMENSIONS, SIZES & SUITABILITY OF DETAILS.

DURADEK LTD.

CANADA
UNITED STATES

Bus: (604) 591-5594
Bus: (816) 421-5830

Fax: (604) 591-3100
Fax: (816) 421-2924

SYSTEM:
TILEDEK SYSTEM

DATE: 25/08/08
REV. DATE: 22/11/10

DRAWING No.:
OS-1T



PRE-FINISHED METAL DRIP EDGE

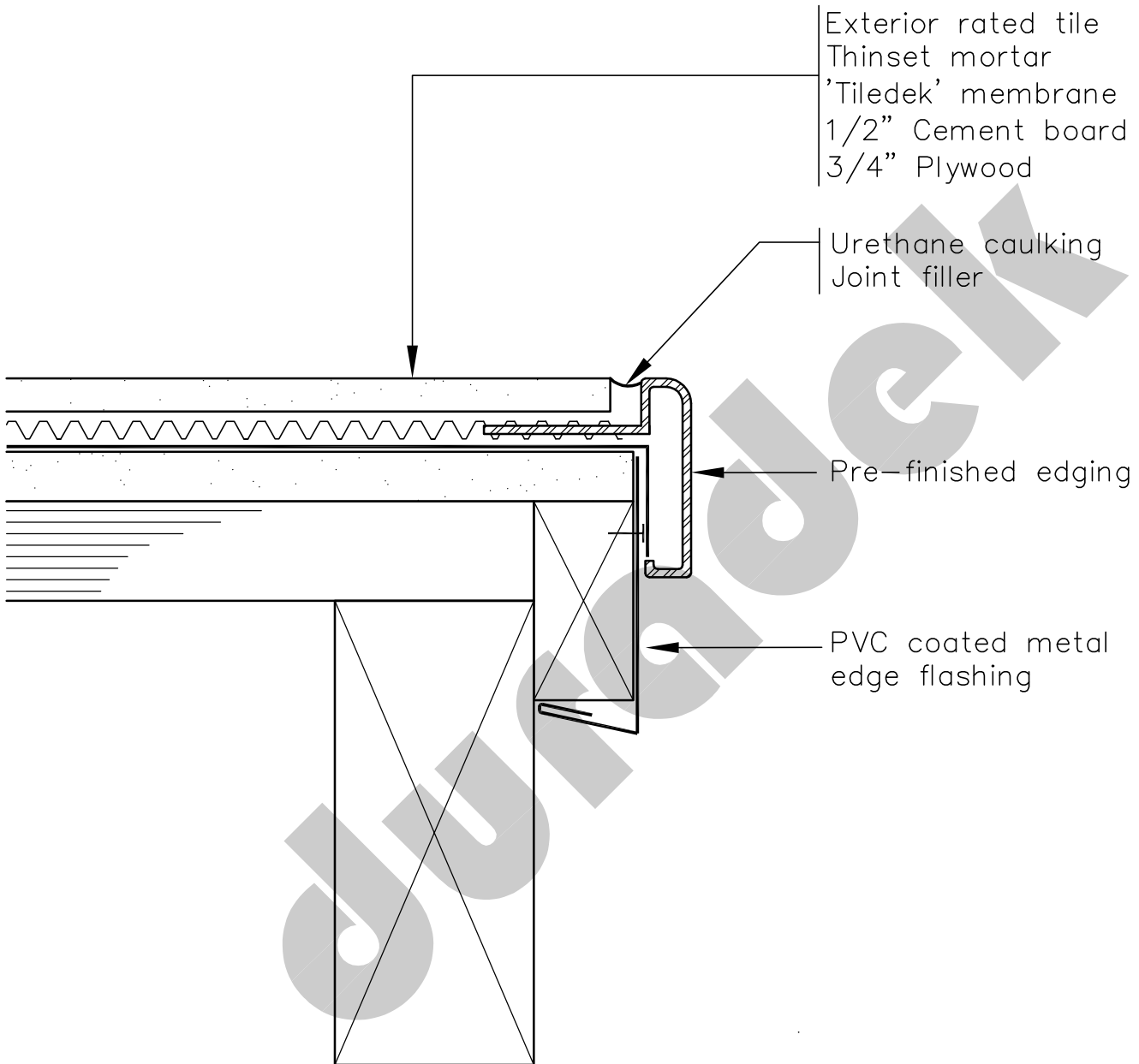

NOTE:

AS A SUPPLIER OF FINISHED PRODUCT ONLY, DURADEK LTD. DOES NOT ASSUME RESPONSIBILITY FOR ERRORS IN DESIGN, ENGINEERING, OR DIMENSIONS. THE ARCHITECT, ENGINEER, SPECIFIER, CONTRACTOR OR OWNERS' REPRESENTATIVE MUST VERIFY ALL DIMENSIONS, SIZES & SUITABILITY OF DETAILS.

DURADEK LTD.

CANADA
UNITED STATES

Bus: (604) 591-5594
Bus: (816) 421-5830

Fax: (604) 591-3100
Fax: (816) 421-2924

SYSTEM:
TILEDEK SYSTEM

DATE: 25/08/08
REV. DATE: 22/11/10

DRAWING No.:
OS-2T



CURB

'Tiledek' membrane extends to drip flashing

Pre-finished metal flashing w/
starter strip
both sides

'Tiledek'
Membrane

1/2" Plywood

Pre-mfg.
expansion joint

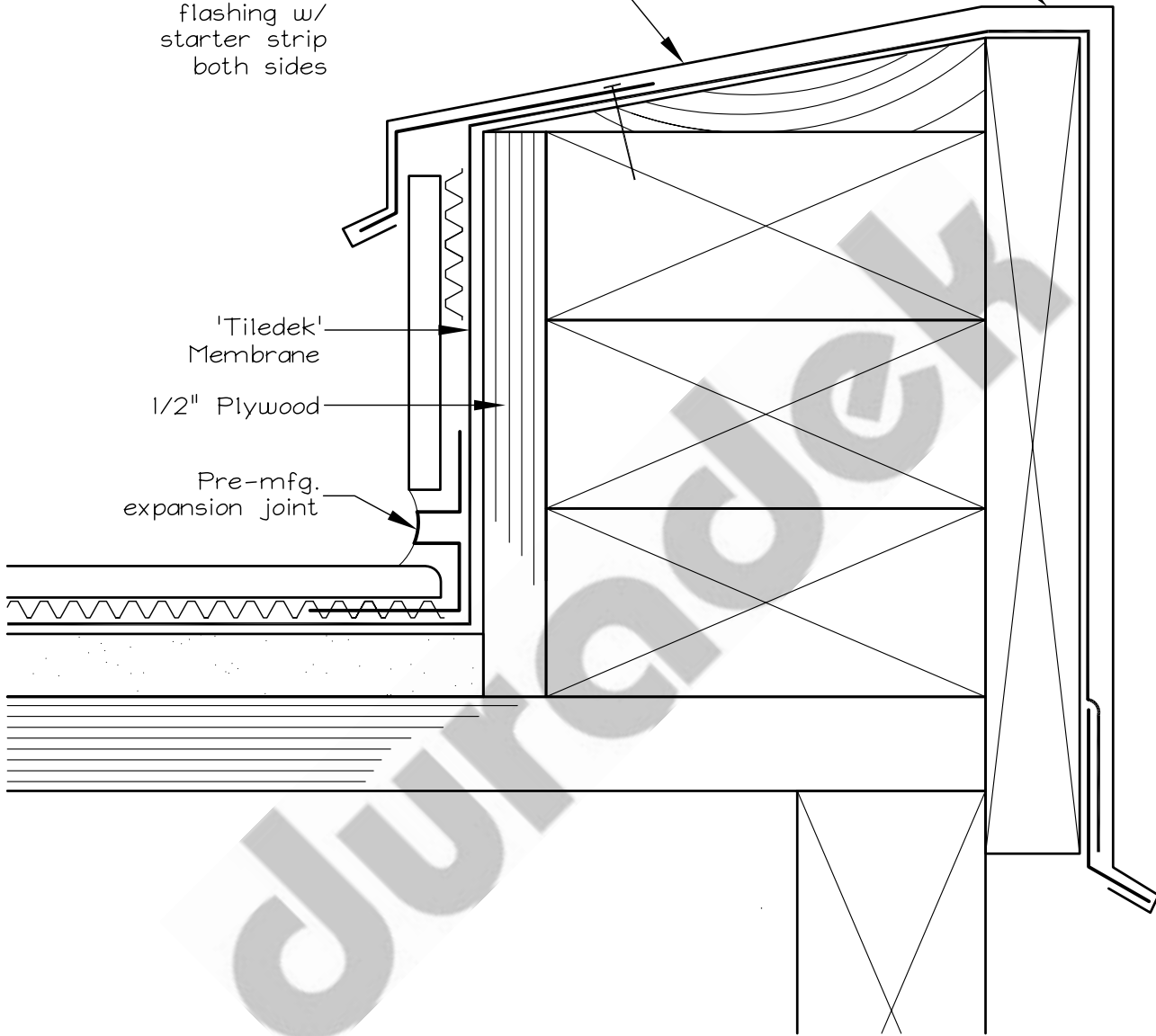

NOTE:

AS A SUPPLIER OF FINISHED PRODUCT ONLY, DURADEK LTD. DOES NOT ASSUME RESPONSIBILITY FOR ERRORS IN DESIGN, ENGINEERING, OR DIMENSIONS. THE ARCHITECT, ENGINEER, SPECIFIER, CONTRACTOR OR OWNERS' REPRESENTATIVE MUST VERIFY ALL DIMENSIONS, SIZES & SUITABILITY OF DETAILS.

DURADEK LTD.

CANADA
UNITED STATES

Bus: (604) 591-5594
Bus: (816) 421-5830

Fax: (604) 591-3100
Fax: (816) 421-2924

SYSTEM:
TILEDEK SYSTEM

DATE: **25/08/08**
REV. DATE:

DRAWING No.:
OS-3T



TILED DRIP EDGE

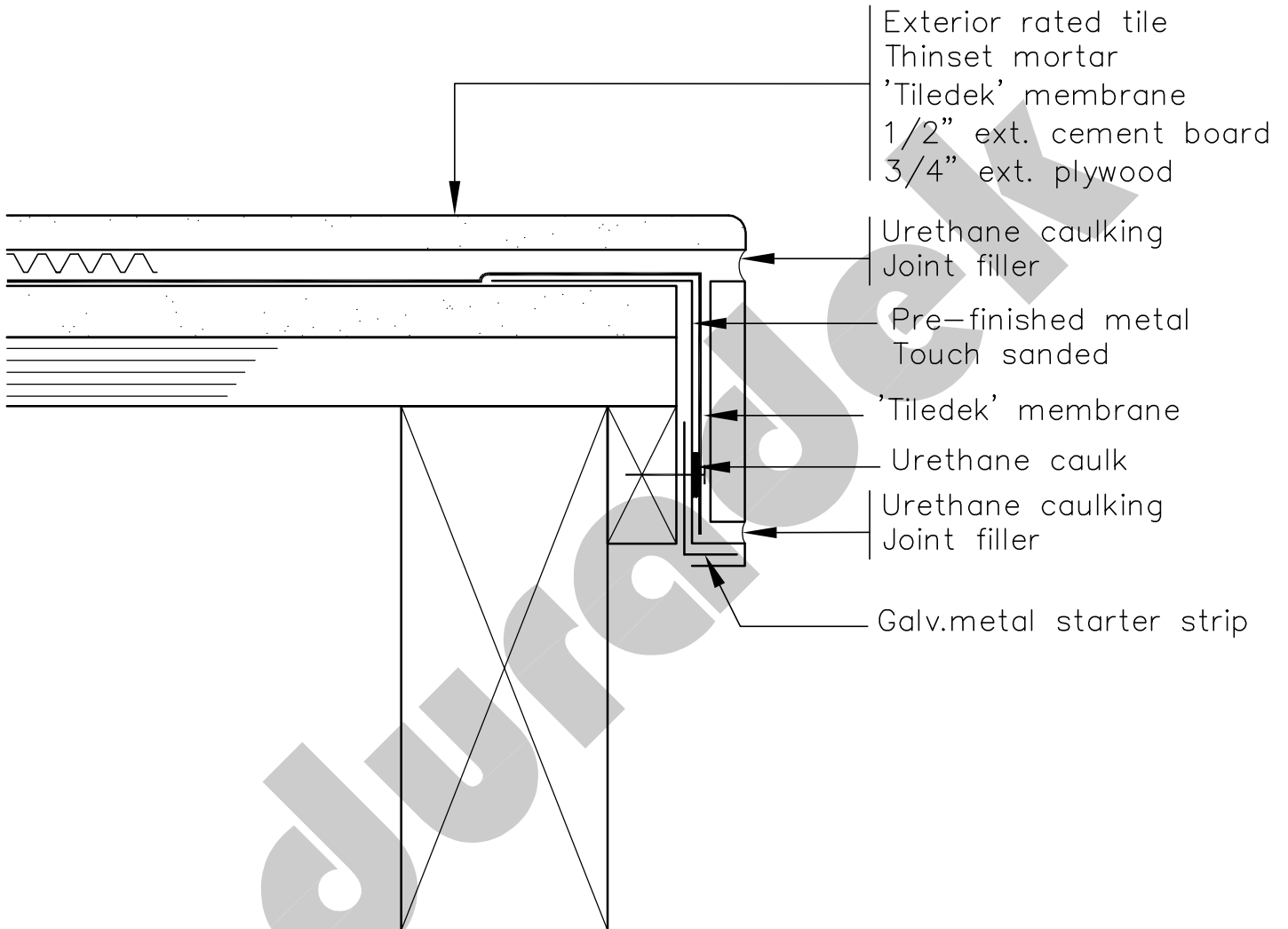

NOTE:

AS A SUPPLIER OF FINISHED PRODUCT ONLY, DURADEK LTD. DOES NOT ASSUME RESPONSIBILITY FOR ERRORS IN DESIGN, ENGINEERING, OR DIMENSIONS. THE ARCHITECT, ENGINEER, SPECIFIER, CONTRACTOR OR OWNERS' REPRESENTATIVE MUST VERIFY ALL DIMENSIONS, SIZES & SUITABILITY OF DETAILS.

DURADEK LTD.

CANADA
UNITED STATES

Bus: (604) 591-5594
Bus: (816) 421-5830

Fax: (604) 591-3100
Fax: (816) 421-2924

SYSTEM:
TILEDEK SYSTEM

DATE: 25/08/08
REV. DATE: 22/11/10

DRAWING No.:
OS-4T



PRE-FINISHED METAL DRIP EDGE: FOR ASSEMBLIES WITH DRAINAGE MAT

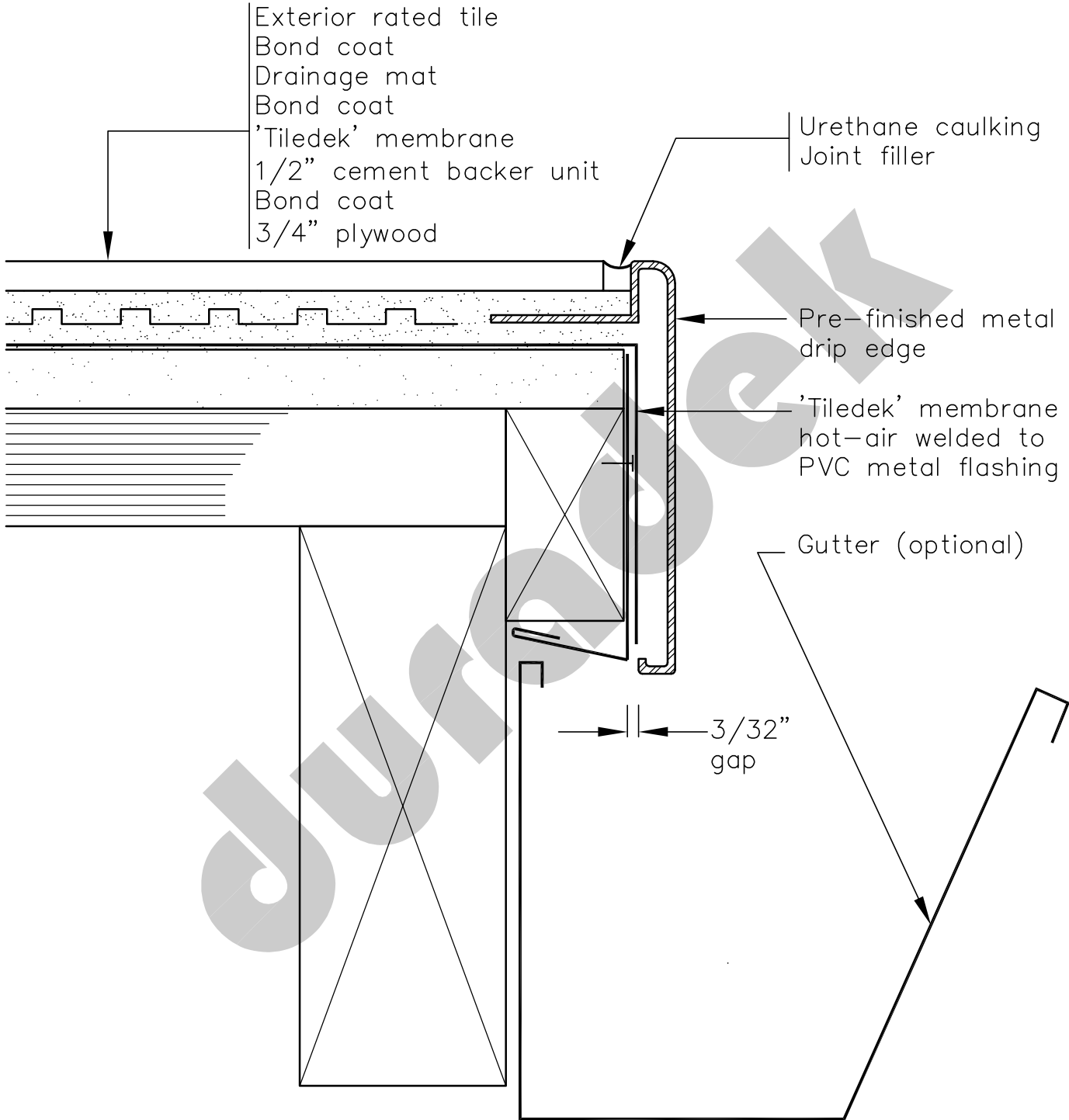

NOTE:

AS A SUPPLIER OF FINISHED PRODUCT ONLY, DURADEK LTD. DOES NOT ASSUME RESPONSIBILITY FOR ERRORS IN DESIGN, ENGINEERING, OR DIMENSIONS. THE ARCHITECT, ENGINEER, SPECIFIER, CONTRACTOR OR OWNERS' REPRESENTATIVE MUST VERIFY ALL DIMENSIONS, SIZES & SUITABILITY OF DETAILS.

DURADEK LTD.

CANADA
UNITED STATES

Bus: (604) 591-5594
Bus: (816) 421-5830

Fax: (604) 591-3100
Fax: (816) 421-2924

SYSTEM:
TILEDEK SYSTEM

DATE: **14/07/09**
REV. DATE: **22/11/10**

DRAWING No.:
OS-5T



WALL FLASHING

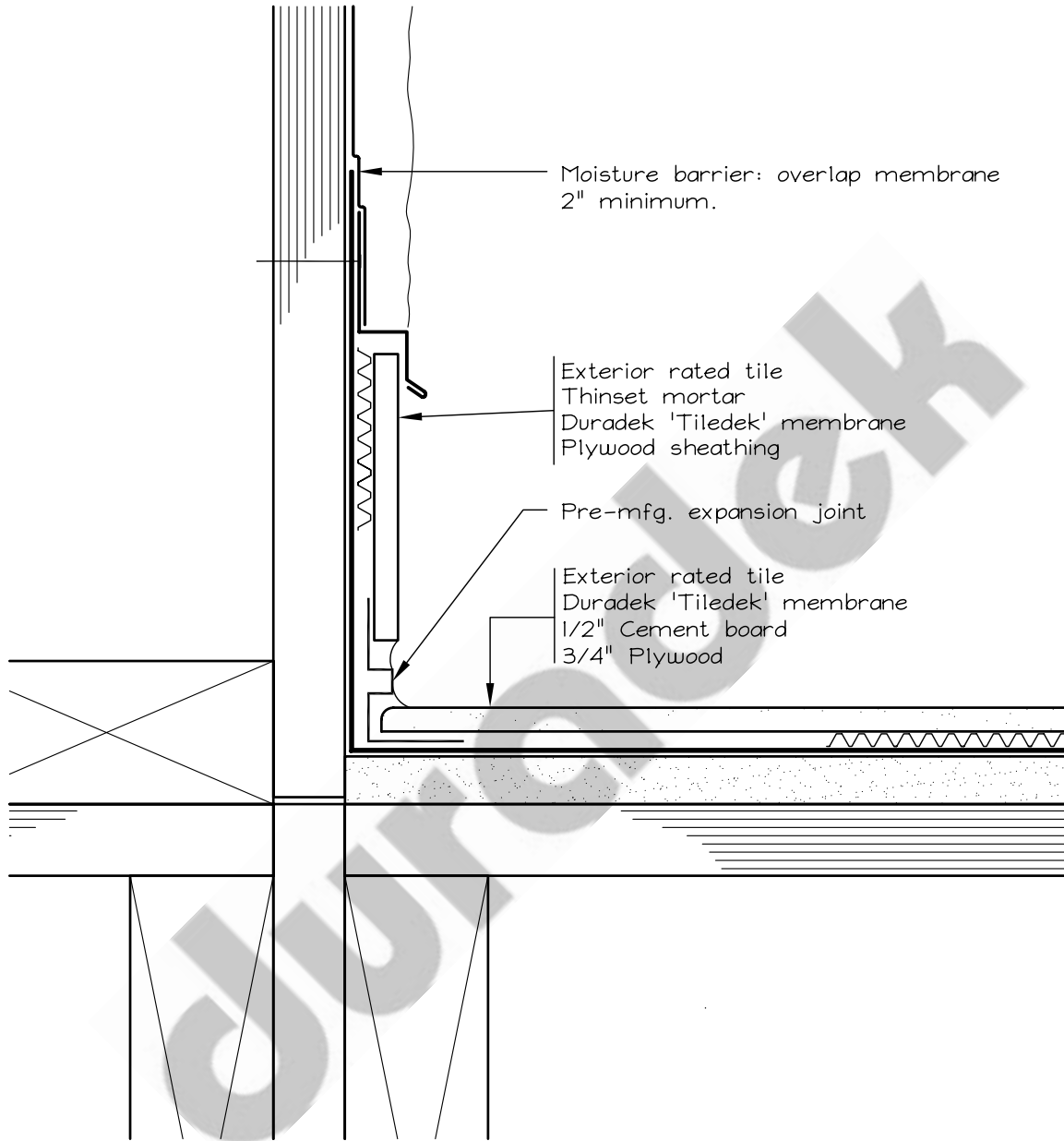

NOTE: AS A SUPPLIER OF FINISHED PRODUCT ONLY, DURADEK LTD. DOES NOT ASSUME RESPONSIBILITY FOR ERRORS IN DESIGN, ENGINEERING, OR DIMENSIONS. THE ARCHITECT, ENGINEER, SPECIFIER, CONTRACTOR OR OWNERS' REPRESENTATIVE MUST VERIFY ALL DIMENSIONS, SIZES & SUITABILITY OF DETAILS.

DURADEK LTD.

CANADA
UNITED STATES

Bus: (604) 591-5594
Bus: (816) 421-5830

Fax: (604) 591-3100
Fax: (816) 421-2924

SYSTEM:
TILEDEK SYSTEM

DATE: **25/08/08**
REV. DATE:

DRAWING No.:
IS-IT



DECK DRAIN

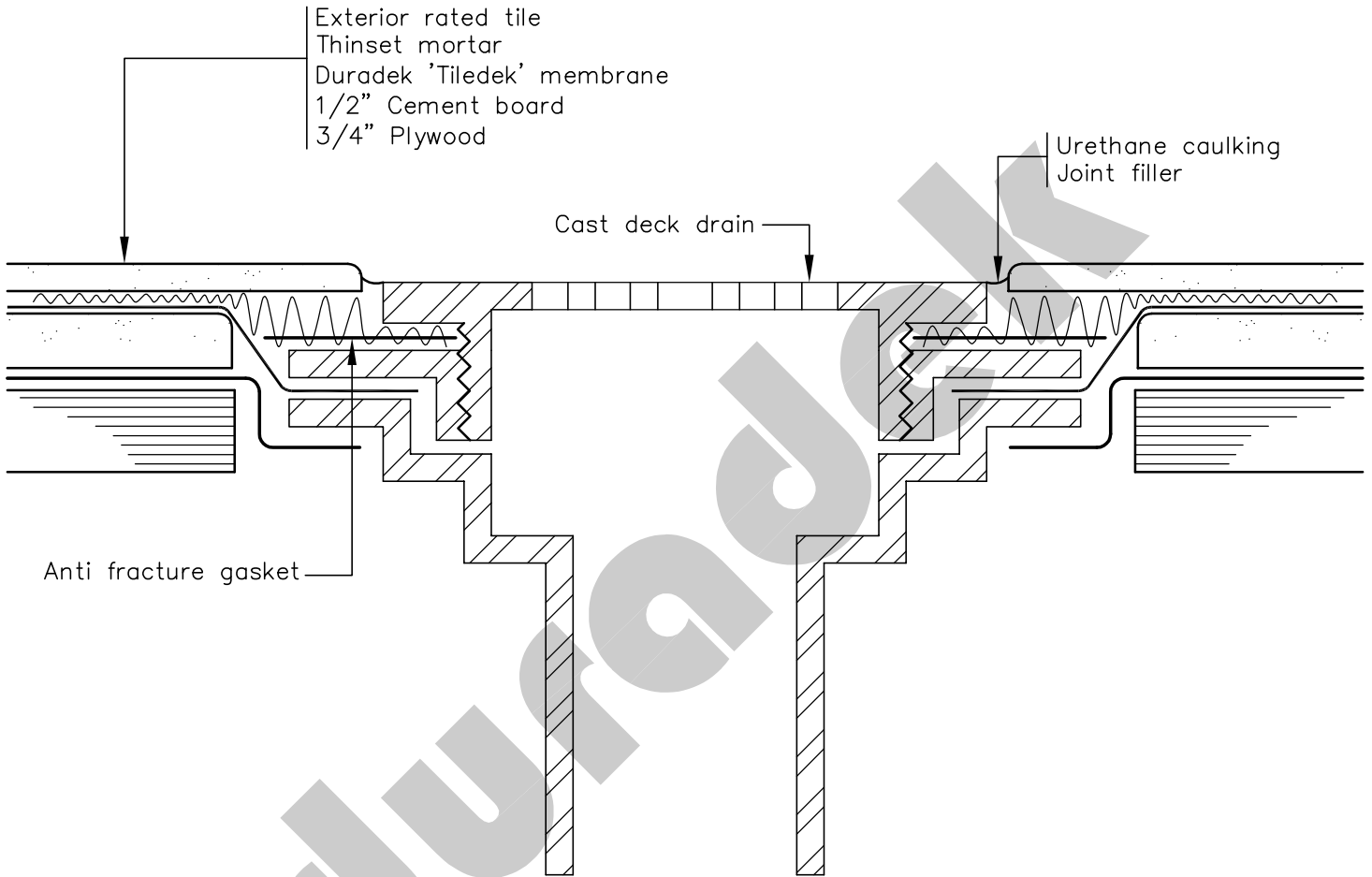

NOTE:

AS A SUPPLIER OF FINISHED PRODUCT ONLY, DURADEK LTD. DOES NOT ASSUME RESPONSIBILITY FOR ERRORS IN DESIGN, ENGINEERING, OR DIMENSIONS. THE ARCHITECT, ENGINEER, SPECIFIER, CONTRACTOR OR OWNERS' REPRESENTATIVE MUST VERIFY ALL DIMENSIONS, SIZES & SUITABILITY OF DETAILS.

DURADEK LTD.

CANADA
UNITED STATES

Bus: (604) 591-5594
Bus: (816) 421-5830

Fax: (604) 591-3100
Fax: (816) 421-2924

SYSTEM:
TILEDEK SYSTEM

DATE: **25/08/08**
REV. DATE: **22/11/10**

DRAWING No.:
DR-1T



GUARDRAIL POST CONNECTION

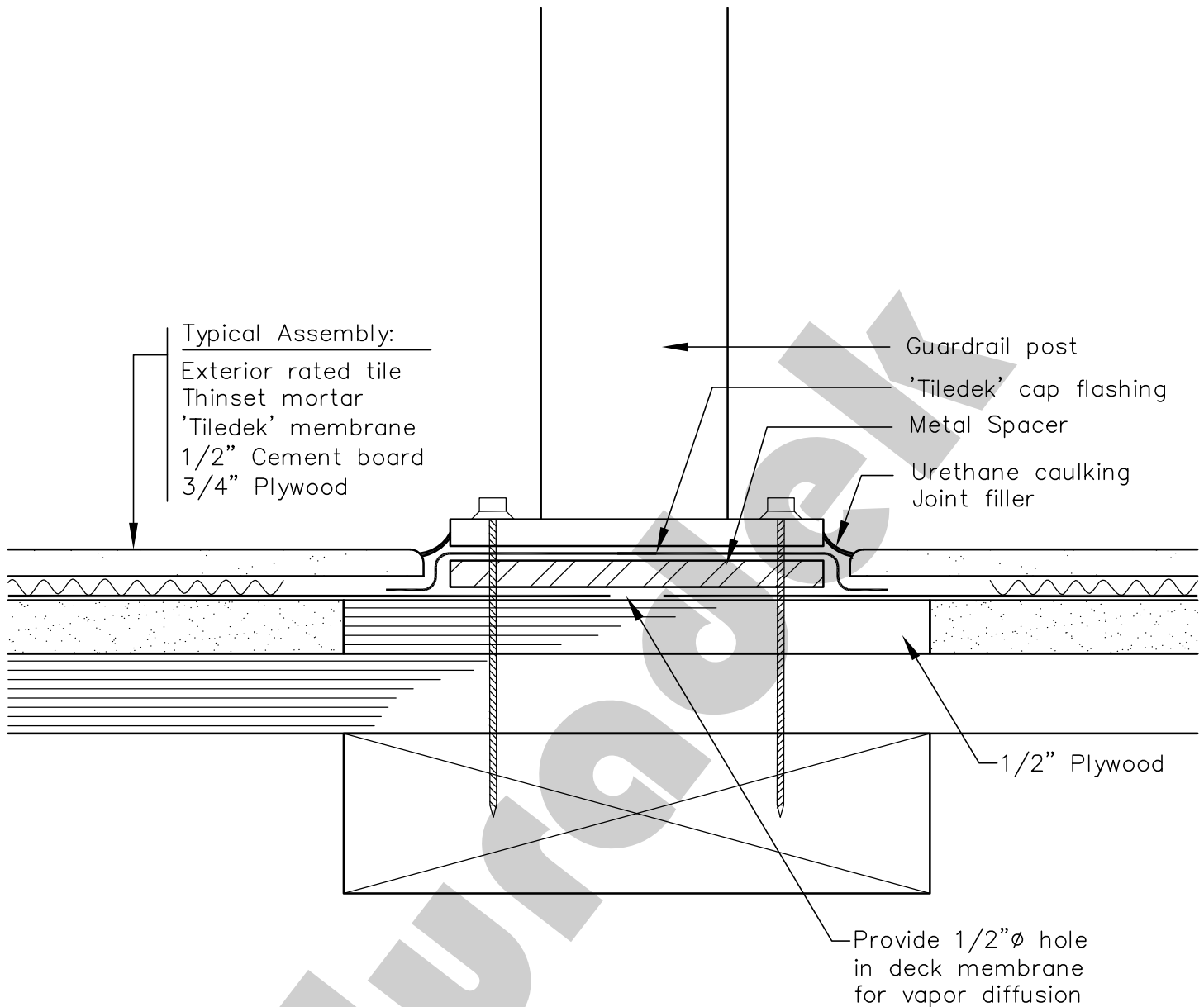

General notes:

- When fastening through membrane(s) drill pilot hole & fill with polyurethane caulking
- Fasten guardrail posts to solid blocking.
- Follow railing manufacturer's installation instructions.

NOTE:

AS A SUPPLIER OF FINISHED PRODUCT ONLY, DURADEK LTD. DOES NOT ASSUME RESPONSIBILITY FOR ERRORS IN DESIGN, ENGINEERING, OR DIMENSIONS. THE ARCHITECT, ENGINEER, SPECIFIER, CONTRACTOR OR OWNERS' REPRESENTATIVE MUST VERIFY ALL DIMENSIONS, SIZES & SUITABILITY OF DETAILS.

DURADEK LTD.

CANADA
 UNITED STATES

Bus: (604) 591-5594
 Bus: (816) 421-5830

Fax: (604) 591-3100
 Fax: (816) 421-2924

SYSTEM:
TILEDEK SYSTEM

DATE: **25/08/08**
 REV. DATE: **22/05/12**

DRAWING No.:
P-1T

