

## DRAIN DETAIL - PVC COATED ALUMINUM DECK DRAIN

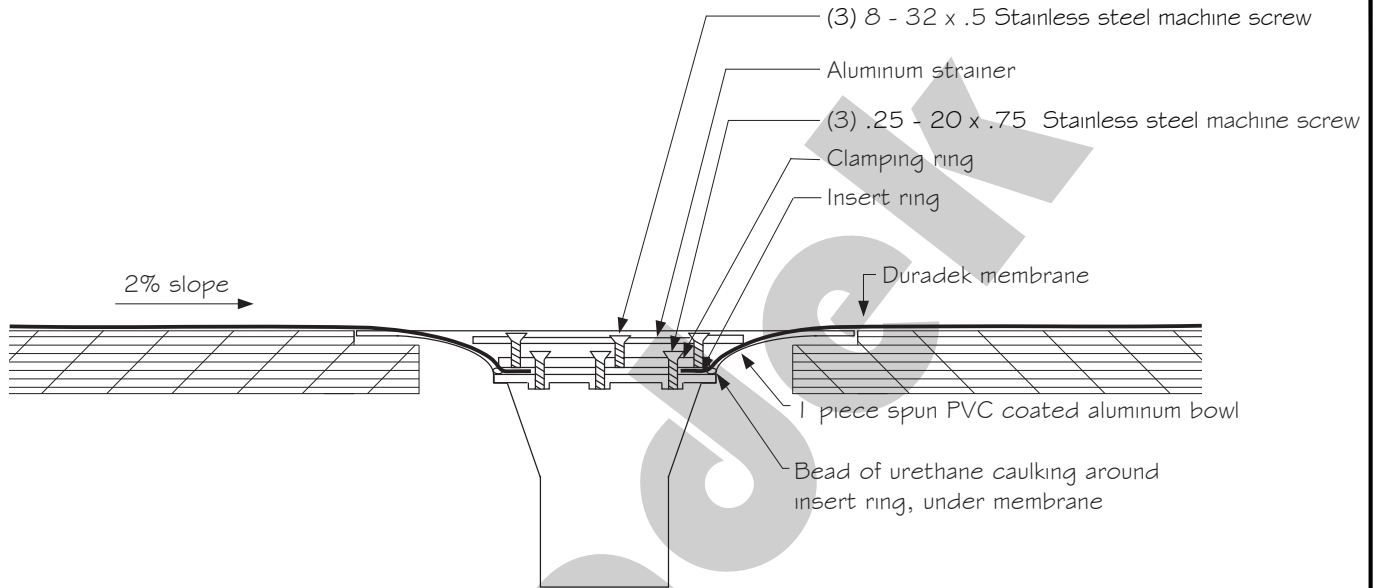

### Installation Notes:

- Drain to be countersunk into plywood deck approximately 1/8".
- Drain body is attached to plywood with 6 x #8 x 1 1/2" screws (or roofing nails). Countersink screw heads with 3/8" high speed countersink drill bit (nic). File off burrs (on back side) created from drilling process.
- Attach drain body to drain pipe with "M-J" coupling (nic). Coupling available in stepped sizes for attachment to both larger and smaller diameter drain pipes (By others).
- Remove strainer and clamping ring before laying in vinyl.
- Apply bead of urethane caulking at edge of insert ring.
- Install clamping ring with (3) screws supplied. Wipe off excess caulking if necessary.
- Install drain cover with (3) screws supplied.

### NOTE:

AS A SUPPLIER OF FINISHED PRODUCT ONLY, DURADEK DOES NOT ASSUME RESPONSIBILITY FOR ERRORS IN DESIGN, ENGINEERING, OR DIMENSIONS. THE ARCHITECT, ENGINEER, SPECIFIER, CONTRACTOR OR OWNERS' REPRESENTATIVE MUST VERIFY ALL DIMENSIONS, SIZES, AND SUITABILITY OF DETAILS, AND ARE IN ACCORDANCE WITH GOVERNING BUILDING CODES.

# DURADEK LTD.

CANADA  
UNITED STATES

Bus: (604) 591-5594  
Bus: (816) 421-5830

Fax: (604) 591-3100  
Fax: (816) 421-2924

SYSTEM:  
ALL ASSEMBLIES

DATE: 22/05/19  
REV. DATE: 25/04/22

DRAWING No.:  
DR-02 - Alt A

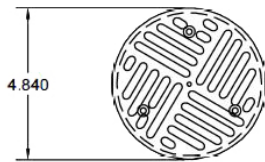

Aluminum Strainer 0.125 - 5052 Aluminum - ASTM B-209

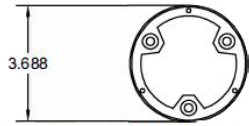

Clamping Ring 0.250 - 5052 Aluminum - ASTM B-209

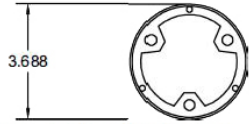

Insert Ring 0.125 - 5052 Aluminum - ASTM B-209

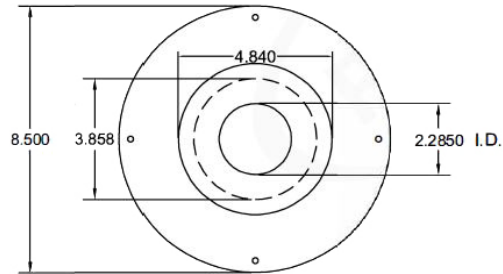

1 Piece Spun Bowl 0.063 - 1100 Aluminum - ASTM B-209

PLAN VIEW



(3) 8 - 32 X .5  
Stainless Steel Machine Screw

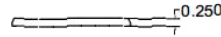

(3) .25 - 20 X .75  
Stainless Steel Machine Screw



(3) 8 - 32  
Press In, Pem Nuts

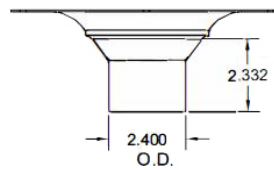

SIDE VIEW

SIZING CHART

DRAIN SIZE	CODE	STEM OD
2"	JVDD2	2.40"
2" PVC COATED	JVDD2C	2.40"

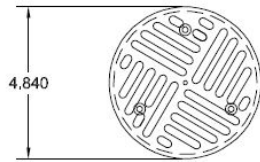

Aluminum Strainer 0.125 - 5052 Aluminum - ASTM B-209

(3) 8 - 32 X .5  
Stainless Steel Machine Screw

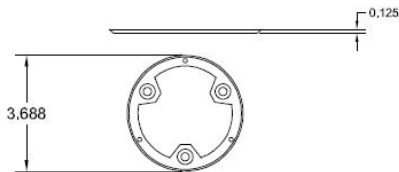

Clamping Ring 0.250 - 5052 Aluminum - ASTM B-209

(3) .25 - 20 X .75  
Stainless Steel Machine Screw

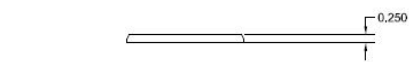

Insert Ring 0.125 - 5052 Aluminum - ASTM B-209



1 Piece Spun Bowl 0.063 - 1100 Aluminum - ASTM B-209

(3) 8 - 32  
Press In, Pem Nuts

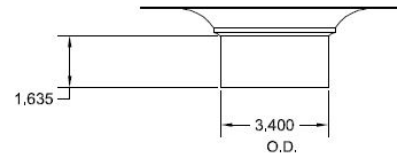

SIDE VIEW

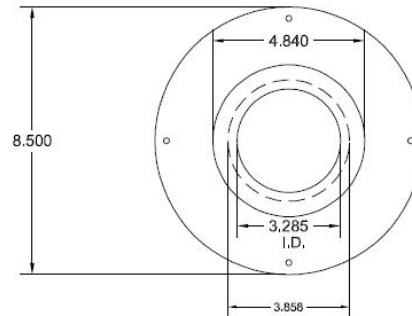

1 Piece Spun Bowl 0.063 - 1100 Aluminum - ASTM B-209

PLAN VIEW

SIZING CHART

DRAIN SIZE	CODE	STEM OD
3"	JVDD3	3.40"
3" PVC COATED	JVDD3C	3.40"